

START HERE

Measure the TV mounting holes.

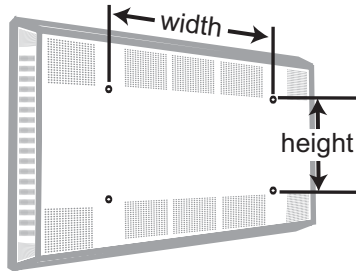

If the width is 26" - 34.50" (66.04 - 87.63 cm), install the Bar Extensions.

If the width is less than 21.50" (54.61 cm), install the Cross Plates.

If the height is 18.50" - 27.50" (47 - 70 cm), install the Bracket Extensions.

More than one adapter may need to be installed.

Bar Extensions

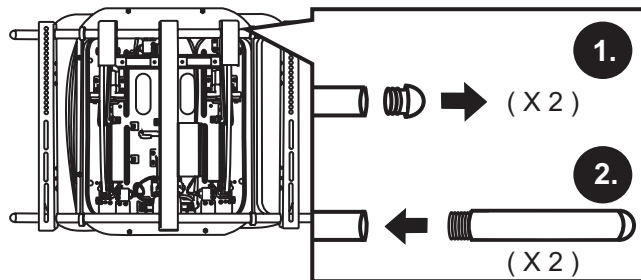

1. Remove the two rubber stoppers from the right side of the X-arm™ cross bars.
2. Screw the bar extensions into the X-arm™ cross bars until they are tight.
3. Loosen the hex screws across the top and bottom of the cross bars, center the cross bars and retighten the hex screws.

Bracket Extensions

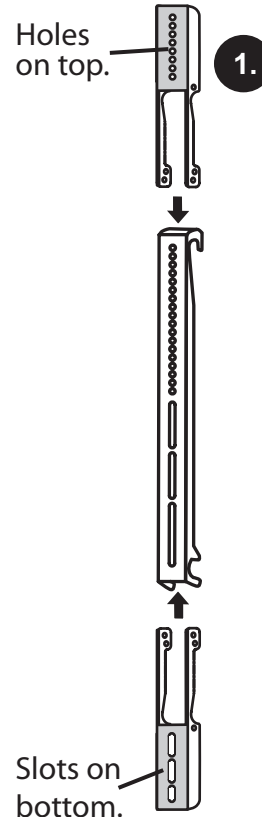

1. Align the bracket extensions containing round holes with the "hook end" of the TV mounting brackets. Align the bracket extensions containing slots with the end of the TV brackets containing slots.
2. Attach the bracket extensions to the TV mounting brackets with the provided screws.
3. Reattach the brackets to the TV with the hook end on the top.

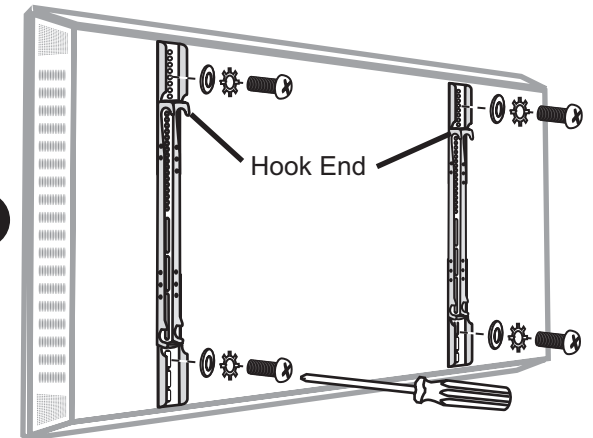

Cross Plates

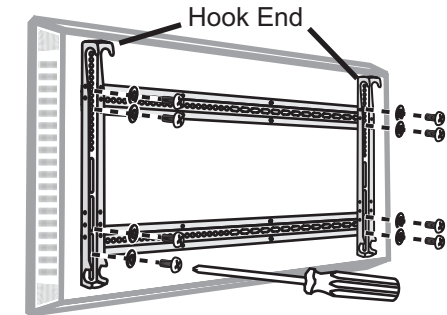
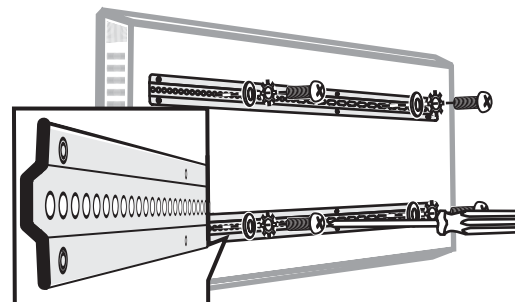
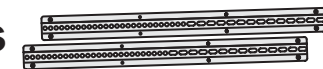

1. Using a washer, lock washer and bolt, attach the two cross plates to the back of the TV. Make sure that the center is flat against the TV.
2. Attach the brackets to the TV. Make sure that the hook end is at the top.